

TenPoint Crossbow Technologies™

VENOM™ ASSEMBLY INSTRUCTIONS

To prevent injury to yourself or others, or damage to your crossbow, read this manual along with all other operating and safety instructions included in your crossbow package before assembling, loading or using the crossbow.

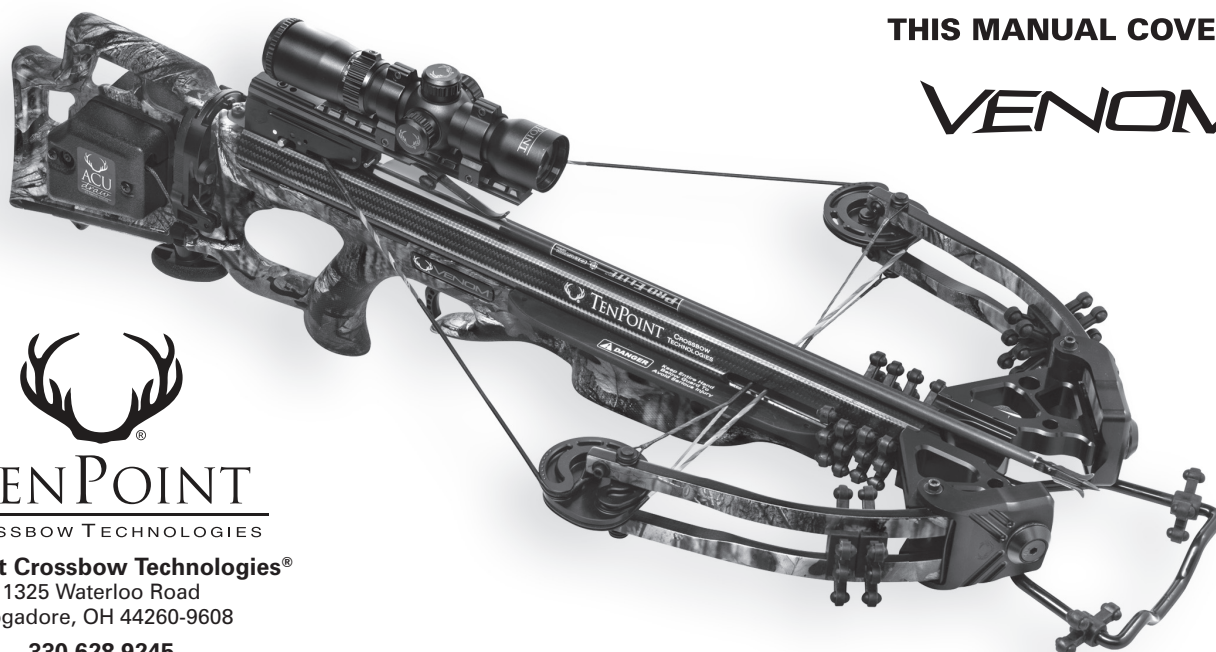

THIS MANUAL COVERS:

VENOM™



TenPoint Crossbow Technologies®
1325 Waterloo Road
Mogadore, OH 44260-9608
330.628.9245
www.tenpointcrossbows.com

VENOM ASSEMBLY

The Venom crossbow is easy to assemble. Basically, you only have to bolt the bow assembly to the stock assembly, install the foot stirrup and you are ready to shoot. Once assembled correctly, your crossbow is pre-sighted for 20-yards.

Lay out the contents of your crossbow box in front of you. Be certain the box contains all of the following items before beginning assembly (photo 1):

- One (1) complete stock assembly
- One (1) complete bow assembly
- One (1) cable saver
- One (1) VIBRA-CUSH™ (pre-installed at factory)
- One (1) large clear plastic bag containing paperwork (including a warranty card) and one (1) other sealed plastic bag containing the main assembly bolt, Allen wrenches and a sample tube of oil.

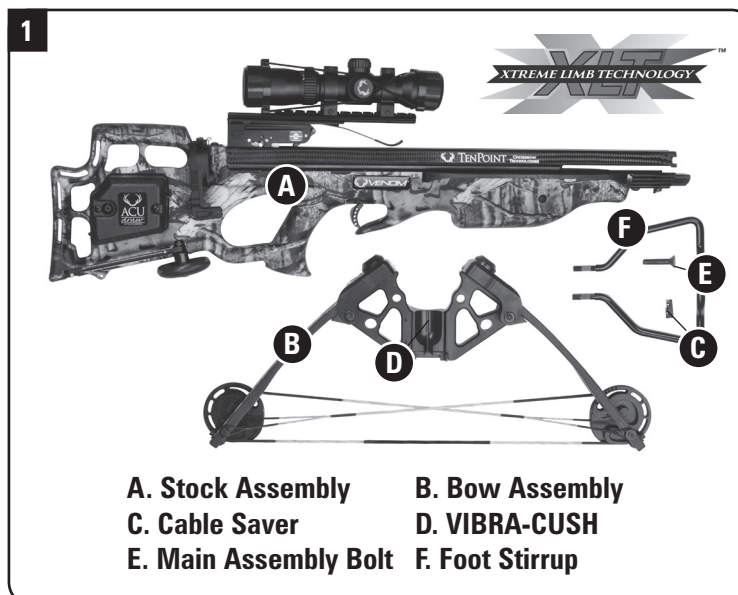

A. Stock Assembly B. Bow Assembly
C. Cable Saver D. VIBRA-CUSH
E. Main Assembly Bolt F. Foot Stirrup

ASSEMBLY STEPS

1. Attach the cable saver to the cables. **Note: Do not attach the bow assembly to the stock assembly without the cable saver – cable damage will occur and the crossbow will be unsafe to shoot.**

- When viewing the cable saver from the side, with its “dish” (concave surface) facing up, notice that one of the two cable notches is positioned deeper into the cable saver (closer to the “dish”) than the other.
- Because the cables cross, one rests on top of the other. The top cable goes into the deeper of the two cable saver notches and the bottom cable goes into the shallower cable saver notch (photo 2), allowing the cable saver to maintain a relatively level position on top of the two cables.
- Before sliding the cable saver into the barrel’s cable slot, apply a drop of Flight Groove / Trigger Lube (HCA-111) or Microlon’s® Precision Oiler (HCA-11106) to the “dish” (concave surface) or top of the cable saver (the part that comes in contact with the underside of the barrel’s arrow flight groove).

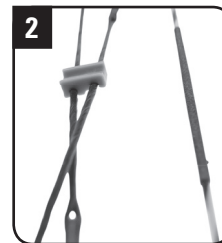

Make certain your cables go into the correct slots in your cable saver.

2. Attach the bow assembly to the stock assembly as follows:

- Position the bowstring on top of the barrel’s flight deck while you insert the cable saver (concave side up) and the cables into the barrel’s cable slot. The cable saver’s concave groove (“dish”) should mate with the underside of the barrel’s arrow flight groove (photo 3).
- Install Bowjax barrel dampeners. Ensure that the pre-installed VIBRA-CUSH is in place with its cutout side facing the barrel (photo 4).
- Pull the bow assembly toward the trigger assembly until the riser location rod, protruding from the front of the barrel and through the VIBRA-CUSH, mates with the hole in the riser. Do not twist or rock the bow assembly to the extent that you rub the cables along the slightly sharp edges of the barrel’s cable slot. You do not want to cut any of your cable strands. Pulling up and back slightly on the bowstring may assist you in seating the bow assembly onto the stock assembly (photo 5).
- After you make sure the main assembly bolt’s locking setscrew is loosened, insert the main assembly bolt. You may need to use your free hand to lift the string off the barrel (sometimes as much as an inch) until the hole in the end of the riser rod and the assembly bolt hole in the riser are perfectly aligned. Then, finger-tighten the bolt at least a few turns.
- Finish tightening the bolt using your Allen wrench while continuing to lift the string off the barrel (photo 6). If the alignment is correct, you will have no difficulty. Do not use a cheater-bar when tightening the main assembly bolt.
- Insert the foot stirrup into the two receiving holes located at the front of the riser. Make sure the “valley” in the stirrup’s foot-pad points down so that it does not block the arrow’s flight path.

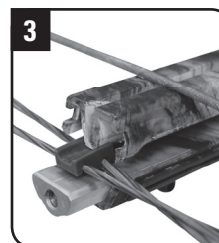

The bow string sits on the barrel's flight deck while the cable saver and cables slide into the cable slot.

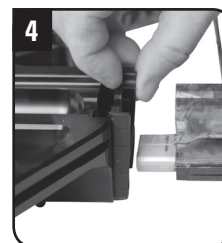

The VIBRA-CUSH goes between the riser and the barrel, cutout side facing the barrel.

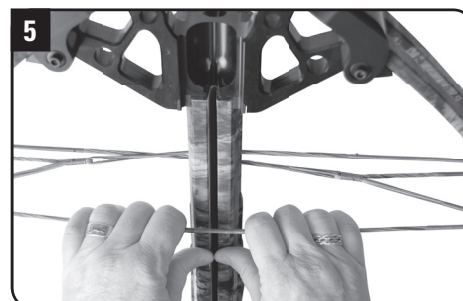

Pull up and back slightly on the bow string to seat the bow assembly.

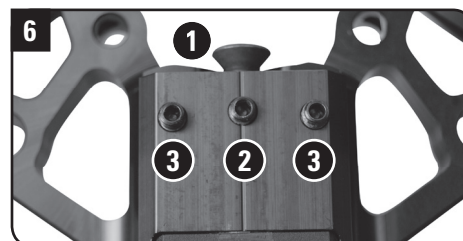

1. Main Assembly Bolt
2. Main Assembly Bolt's Locking Setscrew
3. Foot Stirrup Locking Setscrew

Note: If you will be mounting the 3-Arrow Instant Detach Quiver, follow the directions in the Quiver Mounting section below.

Tighten the locking setscrews located on the bottom of the riser to lock the main assembly bolt and the foot stirrup in place (photo 7).

- You are now ready to test-fire your crossbow and fine-tune your sights (**See appropriate Cocking, Loading & Sighting sections in the general manual**).



Once the foot stirrup is in place, tighten all three setscrews. See below if mounting the 3-Arrow Instant Detach Quiver.

VENOM QUIVER MOUNTING

Your Venom quiver mounting kit is easy to install.

The quiver mounting kit contains the following parts (photo 1):

* If you will be installing the Ambidextrous Side-Mount Quiver Bracket, please refer to the corresponding insert in your Owner's Manual packet.

1. The 3-Arrow Instant Detach Quiver Kit contains the following parts:

- One (1) Quiver
- One (1) Rubber hose (quiver hanger)
- Two (2) Hose plugs
- One (1) Quick disconnect (male) attachment
- Two (2) 3/4-inch oval counter-sink Phillips screws
- One (1) Quick disconnect (female) attachment with lever
- Two (2) Phillips pan-head machine screws
- One (1) Quiver mounting bracket
- Two (2) 7/16-inch Nylock Nuts
- Two (2) 3/4-inch setscrews
- Two (2) 1-inch setscrews (only for Wicked Ridge quiver mounting)

2. Attach the rubber hose to the quiver cup. First, from the bottom of the quiver's cup, insert both ends of the rubber hose approximately two-inches into each hole and insert a hose plug into each end. Then, pull the hose back toward the bottom of the quiver cup and seat the hose plugged ends into the counter-sunk holes (photo 2).

Note: Once inserted, the hose plugs cannot be removed.

3. Position the quick disconnect (male) attachment to the backside of the quiver post, over the 3rd and 4th holes from the quiver cup*. Insert the 3/4-inch oval counter-sink Phillips screws and tighten (photo 3).

* If using the optional TenPoint Ambidextrous Side-Mount Quiver Bracket (HCA-017), position the male attachment over the two holes closest to the quiver cup.

4. Remove the two 1/4-inch setscrews holding the foot stirrup in place (photo 4).

5. Place the quiver's mounting bracket over the two holes you just removed the setscrews from. The mounting bracket holes should face forward toward the foot stirrup (see photo for orientation).

First, insert and tighten the two 3/4-inch setscrews (with Nylock nuts) into the same holes you removed the original setscrews from. Then, tighten the two Nylock nuts until the quiver mounting bracket is secure (photo 5). Use a 7/16-inch open-ended wrench to tighten.

Note: Do not over-tighten.

6. Install the quick disconnect (female) attachment with lever on the quiver mounting bracket using the two Phillips pan-head machine screws. Align the open end with the lever either facing the left or right side of the crossbow, based on personal preference (photo 6).

7. Insert the quiver with male attachment into the quick disconnect (female) attachment with lever, and lock into place (photo 7).

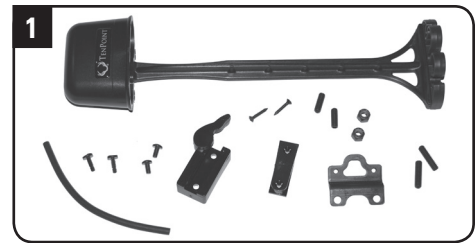

3-Arrow Instant Detach Quiver Mounting Kit

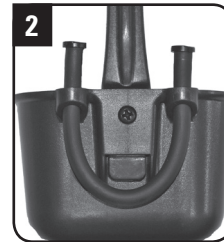

Attach rubber hose to quiver cup.



Attach quick detach (male) attachment.

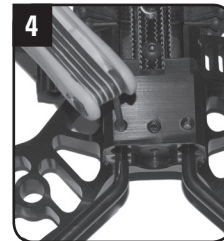

Remove 1/4-inch setscrews holding foot stirrup in place.

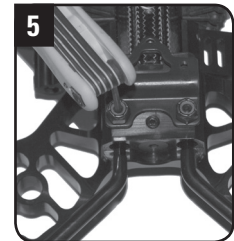

Place the quiver bracket assembly over the two setscrew holes and insert 3/4-inch setscrews and Nylock nuts.

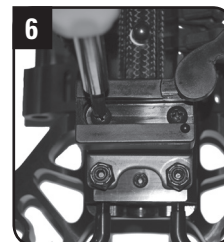

Install the quick disconnect (female) attachment.

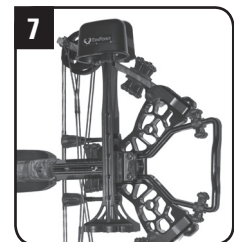

Insert the 3-Arrow Instant Detach Quiver into the female bracket and lock into place with the lever.

SAFETY WINGS

⚠ DANGER Keep your fingers and thumb on your fore-grip hand below the string and arrow flight deck when you fire your crossbow. Otherwise, the bow string will severely injure or amputate them when you pull the trigger.

Note: The Venom comes standard with rubber safety wings which are designed to help keep the shooter's fore-grip fingers and thumb safely below the flight deck while shooting. The wings, which are bedded between the stock and barrel, also serve as noise dampeners. If for any reason they are lost or damaged, contact TenPoint for replacement immediately at www.tenpointcrossbows.com or 330-628-9245.



Proper hand position on the fore-grip.



Safety wings are bedded between the stock and barrel. They help prevent thumb and finger injury and they dampen noise.

STRING CHART

String	Twists
HCA-12014	Pre-twisted (No additional twists needed)

CABLE CHART

Cables	Twists
HCA-12514	Pre-twisted (No additional twists needed)